

3100 Series Design

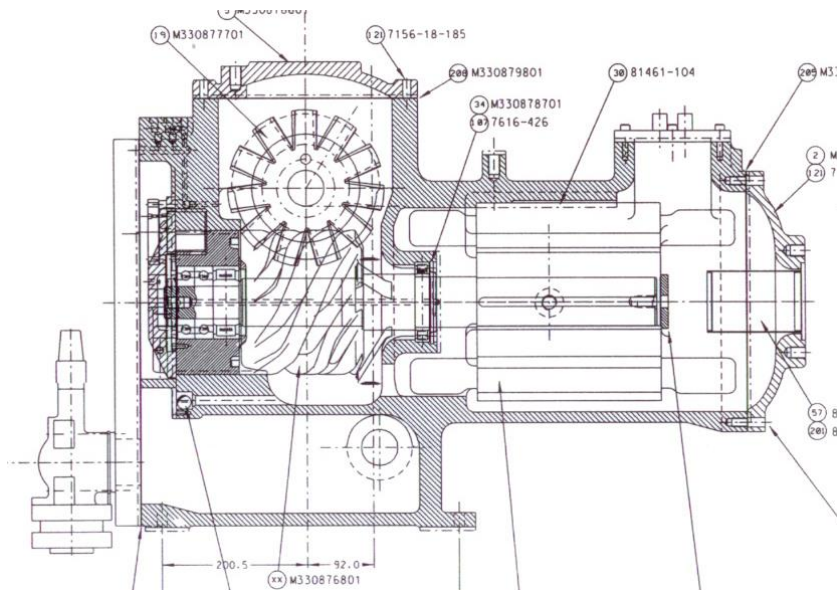
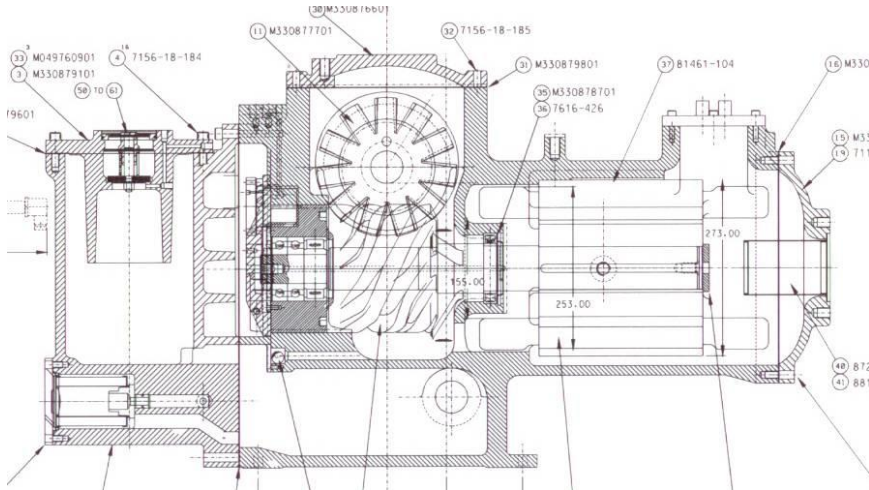

General Features

- Clockwise rotation
- Capacity control
 - 25-100%
 - Single cylinder
 - Single acting cylinder
 - Oil pressure loads/discharge pressure unloads
 - One load/one unload solenoid valve mounted.
 - Spring return to minimum load.
- Single oil feed to main injection, bearings and capacity control
- No pre lube oil pump required.
- Cannot be used as booster (without modification).
- Dual ports for economiser and liquid injection with muffler
- Internal bypass relief valves 24bar (350psig) R134a, 31bar (450psig) others

HSS3100 exploded view

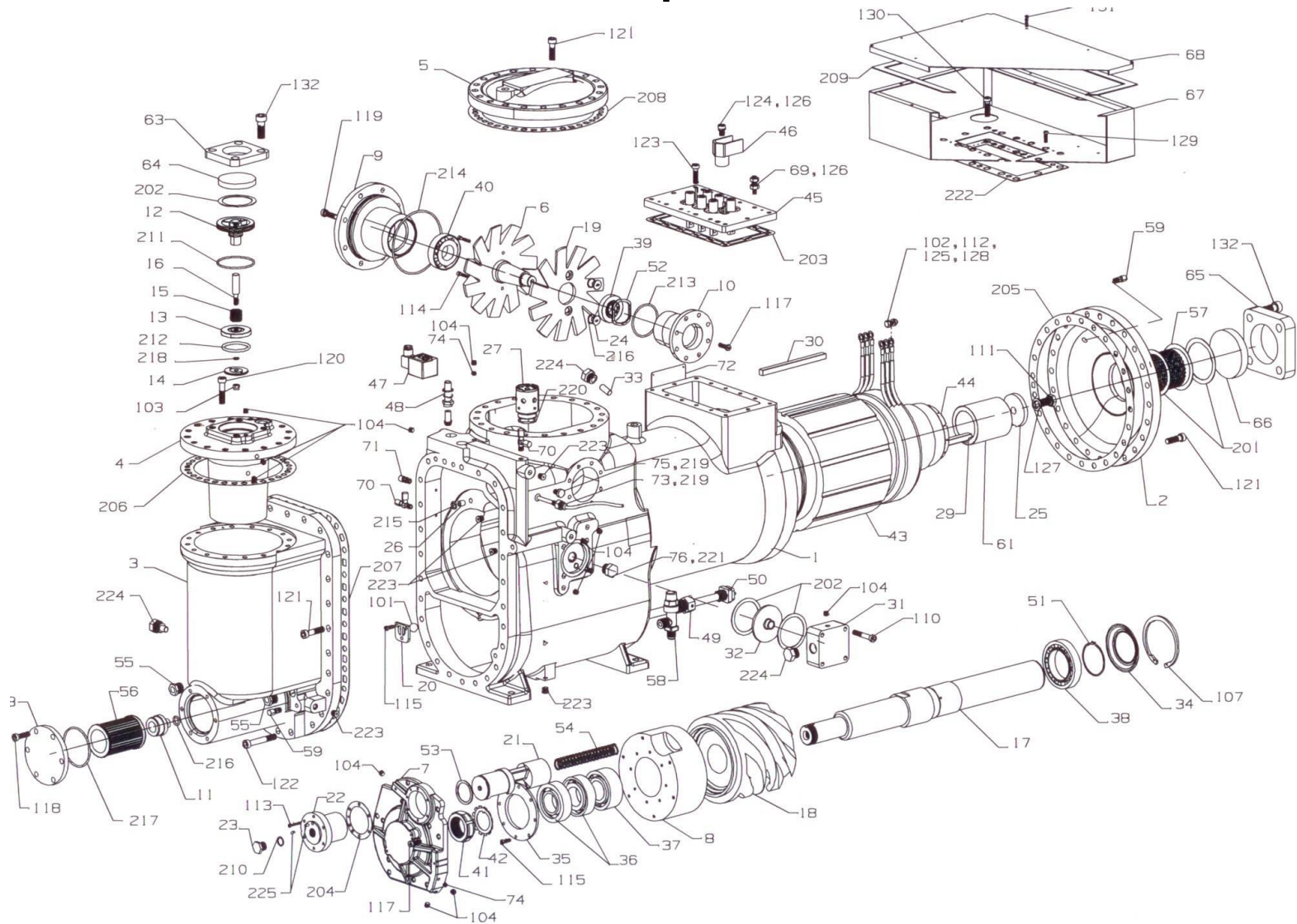

HS3100 Capacity Control

